

THIS DRAWING IS UNPUBLISHED. RELEASED FOR PUBLICATION
 © COPYRIGHT BY TYCO ELECTRONICS CORPORATION. ALL INTERNATIONAL RIGHTS RESERVED.

LOC	DIST	REVISIONS			
P	LTR	DESCRIPTION	DATE	DWN	APVD
G	14	H1	REVISED PER ECR-08-022232	06OCT08	HMR TM

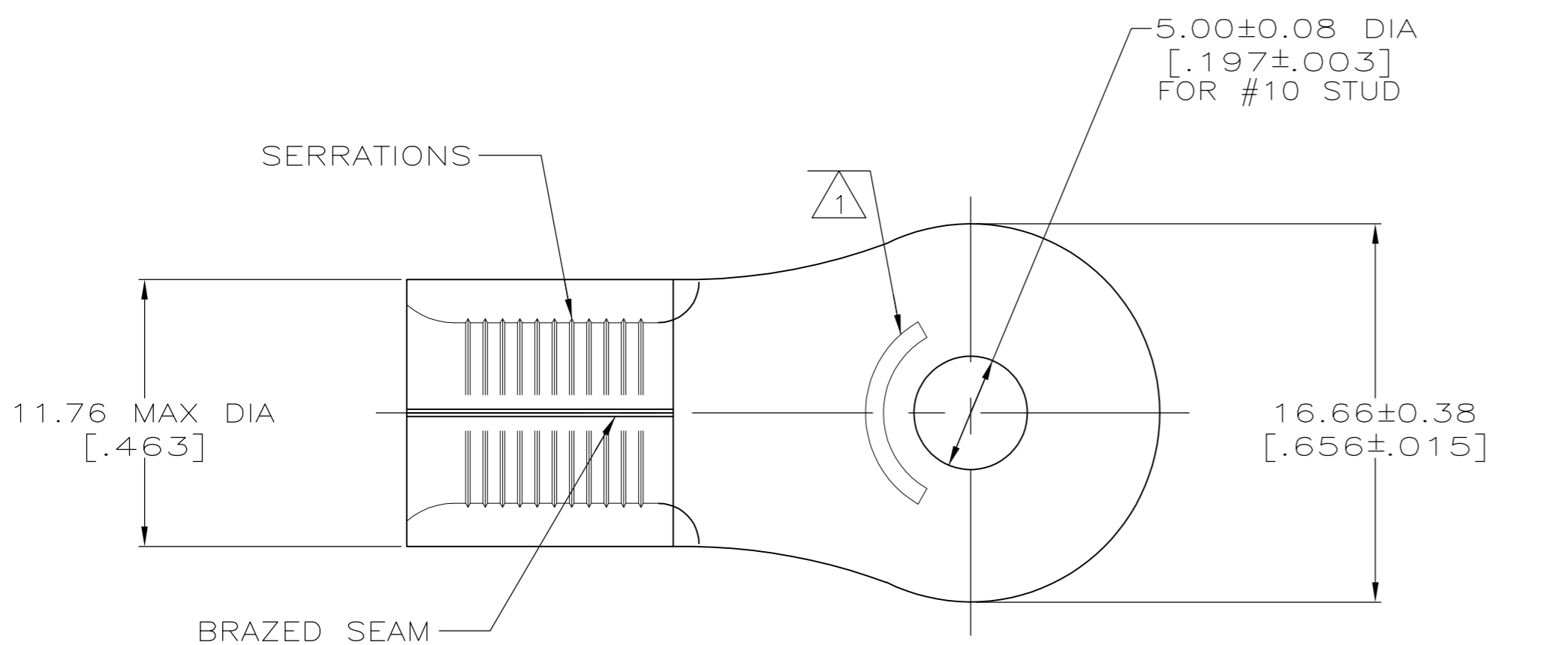

AMP
WIRE RANGE

4 AWG
SOLID OR STRANDED

- 1 STAMP AMP 4* APPROX AS SHOWN
- 2 UL LISTED E13288, 4 AWG STRANDED
- 3 CSA CERTIFIED LR7189, 4 AWG SOLID OR STRANDED
- 4 TIN PLATE 0.00254 [.000100] MIN THK PER ASTM B545
- 5 TIN-LEAD (60-40) PLATE 0.00254 [.000100] MIN THK PER SAE-AMS-P-81728
- 7 PRELIMINARY - NOT FOR PRODUCTION

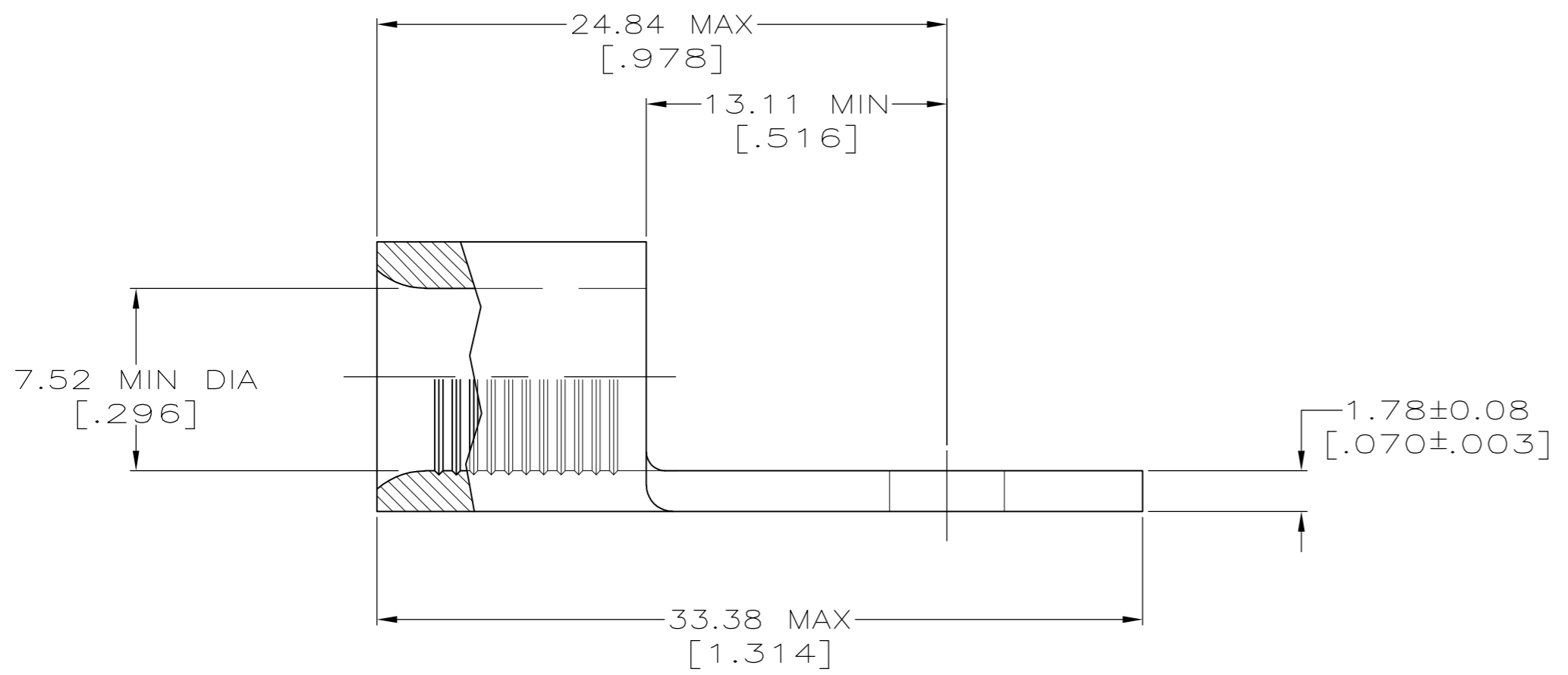

APPROVALS	FINISH	QTY	PACKAGE TYPE	PART NO.
2 3	4	25	LOOSE PIECE, BOX	8-33468-3
---	5	25	LOOSE PIECE	7 33468-1
2 3	4	100	LOOSE PIECE	33468

THIS DRAWING IS A CONTROLLED DOCUMENT.

DWN	TA BRINKMAN	3-29-93	Tyco Electronics Corporation Harrisburg, PA 17105-3608								
CHK	DA PATTERSON	3-29-93									
APVD	JL MECKLEY	3-29-93									
PRODUCT SPEC											
APPLICATION SPEC			NAME								
			TERMINAL, RING TONGUE, SOLISTRAND								
MATERIAL	ASTM B152	FINISH	SEE TABLE	SIZE	A2	CAGE CODE	00779	DRAWING NO	C=33468	RESTRICTED TO	-
CUSTOMER DRAWING		SCALE	4:1	SHEET	1 OF 1	REV	H1				

33468